

RST B 20 PHI... to
RST B 40 PHI

PNEUMATIC ELEVATING ROTARY INDEXING TABLE WITH HYDRAULIC CUSHIONING,
INTERNAL CONTROL AND

▶ **BALL COUPLING**



*Diagram illustrates Tgrooves (optional extra with surcharge)

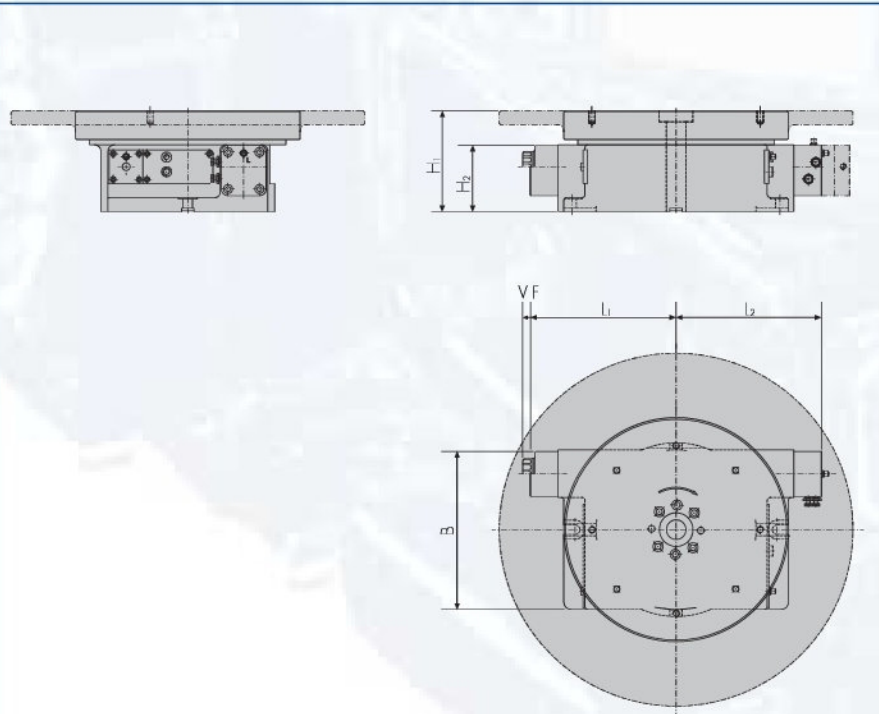

Measurement table		Fixed division F					Variable division V				
Size	Largest division	L ₁	L ₂	B	H ₁	H ₂	L ₁	L ₂	B	H ₁	H ₂
B 20 PHI	TM2 (180°)	172	192	160	110	80	192	192	160	110	80
	TM3 (120°)	134	154	160	110	80	154	154	160	110	80
B 30 PHI	TM2 (180°)	225	238	208	125	84	238	238	208	125	84
	TM3 (120°)	173	186	208	125	84	186	186	208	125	84
B 40 PHI	TM2 (180°)	342	342	312	180	118	355	342	312	180	118
	TM3 (120°)	260	260	312	180	118	273	260	312	180	118

Operating data		20 PHI		30 PHI		40 PHI	
RST PHI/B							
Operating pressure at 6 bar							
Plate diameter	mm	160	200	250	320	400	630
Weight	Kg	20	22	40	44	160	190
Basic division		72		72		120	
Additional divisions on request							
Standard quality		Q24 - Q3		Q24 - Q3		Q24 - Q3	
Max. quality		Q1 on request		Q1 on request		Q1 on request	
Switching time division 4 90°	s	0,65		0,8		1,5	
Switching time division 8 45°	s	0,42		0,5		1,2	
Switching time division 12 30°	s	0,28		0,3		1	
Max. conveyance weight centralised	Kg	50		150		450	
Torque M _t	Nm	21		37		92	
Elevating force F _x	N	1800		2600		7600	
Interlocking force F _y	N	3250		7870		17720	
Interlocking moment against distortion M _z	Nm	228		849		3334	
Tilting M _z	Nm	186		733		2991	
Compressed air supplies		R 1/8"		R 1/4"		R 1/4"	